

Architectural Essentials™ Accessories

INSTALLATION MANUAL



by CRANE

www.ExteriorPortfolio.com

INSTALLATION OF 3-PIECE DECORATIVE CORNER SYSTEM

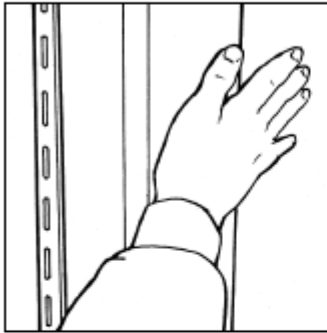

Figure 1

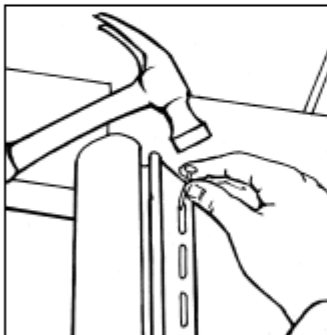

Figure 2

- 1) Place the Corner Connector in position, allowing a $\frac{1}{4}$ " gap between the top of the connector and the eave or soffit. Position a nail at the top of the upper slot on both sides of the connector, leaving a $\frac{1}{32}$ " gap between the nail heads and the connector. The connector hangs from these nails. The remainder of the nails should be in the center of the nail slots at 10" to 12" intervals. The Corner Connector should extend $\frac{3}{4}$ " below the siding starter strip. It is important that the connector is plumb (i.e. vertically straight). (Figure 1)
- 2) Install $3\frac{1}{2}$ " or 5" lineal into the connector by starting at the top or the bottom and pushing the locking leg of the lineal into the channel of the corner connector. The lineal must also be $\frac{1}{4}$ " from the eave or soffit. Nail the lineals in the same manner as the connector (Figure 2). Repeat on other side. *Be sure not to nail tight. Hang the lineals and nail loosely.*

WINDOW LINEAL INSTALLATION

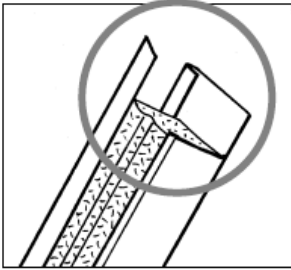

Figure 1

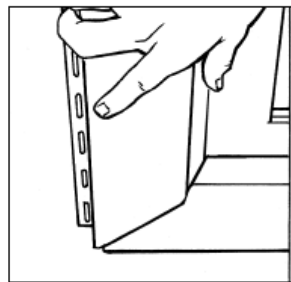

Figure 2

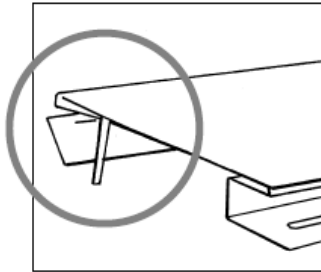

Figure 3

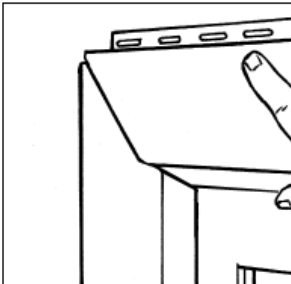

Figure 4

LINEAL STARTER STRIP

- 1) Measure the width and height of the window. Subtract $\frac{1}{8}$ " from the measurements. Cut and install lineal starter strip, nailing loosely every 8" to 10".

BOTTOM LINEAL

- 1) Measure the width of the window. Add 7" for $3\frac{1}{2}$ " lineals and 10" for 5" lineals.
- 2) Measure and cut a $\frac{7}{8}$ " notch off the window J receiver on both ends of the lineal. Cut the same $\frac{7}{8}$ " notch out of the J pocket of the lineal, again on both ends. Cut back the foam to these notches. (Figure 1)
- 3) Snap lineal onto bottom of window and tack temporarily into place.

SIDE LINEALS

- 1) Measure the height of the window and, as with the bottom lineal, add 7" for $3\frac{1}{2}$ " lineals and 10" for 5" lineals.
- 2) Make the same $\frac{7}{8}$ " notches to the top of the side lineal as shown in figure 1. Cut back the foam to the notch.
- 3) On the opposite end, measure back $3\frac{1}{2}$ " on the inside or window side and make a mark. Using snips, cut a 45° angle from the outside corner to your mark. (Figure 2)
- 4) Make a $\frac{7}{8}$ " notch in the J pocket.
- 5) Cut back the foam to the inside of the angle.
- 6) Install the side lineal working the angle over the bottom lineal.
- 7) Nail loosely every 8" to 10".
- 8) Repeat for other side.

TOP LINEAL

- 1) Using the width measurement, add the appropriate amount and cut to length.
- 2) Measure back $3\frac{1}{2}$ " on the window side and make a mark. Using snips, cut a 45° angle from the outside corner to the mark.
- 3) Cut a $\frac{3}{4}$ " notch inside the pocket, as you would with J channel, to form a rain tab and bend it down. Repeat this process on the other end. Cut the foam back to the insides of the angles. (Figure 3)
- 4) Install the top lineal placing the angles over the side lineals. Nail loosely every 8" to 10". (Figure 4)

Finish by nailing bottom lineal loosely every 8" to 10".

WINDOW LINEAL INSTALLATION WITH SILL LINEAL

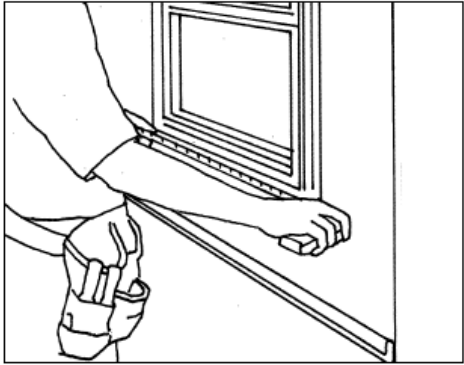

Figure 1

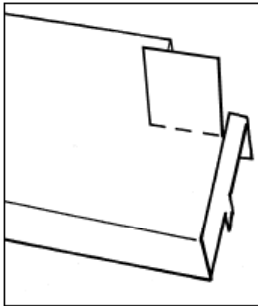

Figure 2

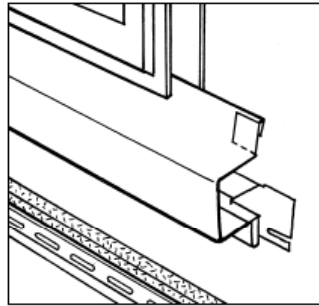

Figure 3

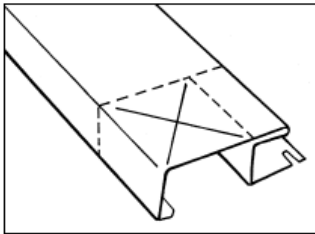

Figure 4

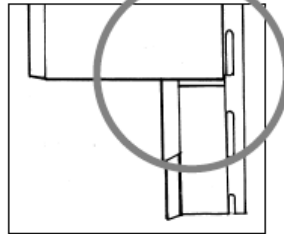

Figure 5

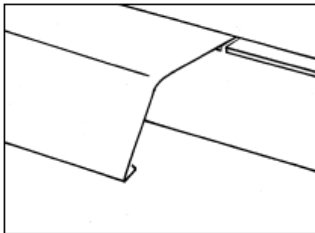

Figure 6

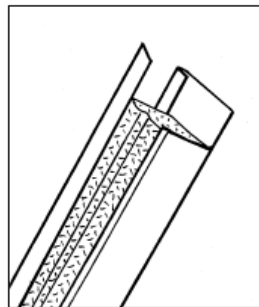

Figure 7

LINEAL STARTER STRIP

- 1) Measure the width and height of the window. Subtract $\frac{1}{8}$ " from the measurements. Cut and install lineal starter strip, nailing loosely every 8" to 10".

SILL LINEAL

- 1) Using the width measurement of the window, add 7" for $3\frac{1}{2}$ " lineals or 10" for 5" lineals. (Figure 1)
- 2) Cut *Sill Lineal* to appropriate length.
- 3) On the top of the *Sill Lineal*, measure $\frac{7}{8}$ " from the end and $1\frac{1}{4}$ " back from the starter side leg. Make a cut at the $\frac{7}{8}$ " mark back to the $1\frac{1}{4}$ " mark. Remove the locking leg. Bend the remaining flap up. (Figure 2)
- 4) On the bottom or nail hem area of the *Sill Lineal*, create a $\frac{7}{8}$ " notch in the "pocket" as you would a J channel piece.
- 5) Repeat this process on the opposite end of the *Sill Lineal*.
- 6) Snap Sill into place. (Figure 3)

SIDE LINEALS

- 1) Using window height measurement, add $6\frac{1}{8}$ " for $3\frac{1}{2}$ " lineals or $7\frac{5}{8}$ " for 5" lineals. Cut product to appropriate length.
- 2) Measure $2\frac{5}{8}$ " from what will be the bottom and $2\frac{5}{8}$ " from the side that will engage into the starter. (Figure 4)
- 3) Cut and remove this area. Continue the crosscut to the edge of the lineal. Widen this cut to make a slit about $\frac{1}{4}$ " wide. (Figure 5)
- 4) Angle cut the inside or starter side leg of the lineal slightly (about $\frac{1}{4}$ "). Trim foam back accordingly. (Figure 6)
- 5) Cut a $\frac{7}{8}$ " notch out of the J pocket.
- 6) On the top, cut a $\frac{7}{8}$ " notch off the inside or starter side leg and an equal $\frac{7}{8}$ " notch out of the inside of the J pocket of the lineal. Trim foam down to the notches. (Figure 7)

WINDOW LINEAL INSTALLATION WITH SILL LINEAL, *continued*

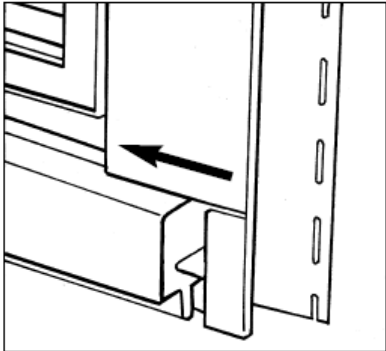

Figure 8

- 7) Install the side lineal sliding the face of the lineal into the J slot of the *Sill lineal*. (Figure 8 & 9)

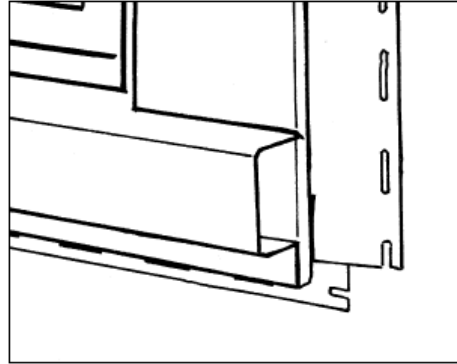

Figure 9

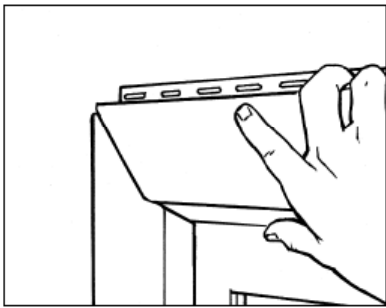

Figure 10

TOP LINEAL

- 1) Measure and cut the lineal. For 3 1/2" lineals add 7" to your window width measurement. For 5" lineals add 10".
- 2) Miter each end of the lineal at a 45° angle.
- 3) Notch the channel 3/4" to form a rain tab and bend it down. (Do this on both ends.)
- 4) Cut back the foam 3 1/2" to the insides of the angles.
- 5) Install the lineal, sliding down over the side lineals and nailing loosely every 8" to 10". (Figure 10)

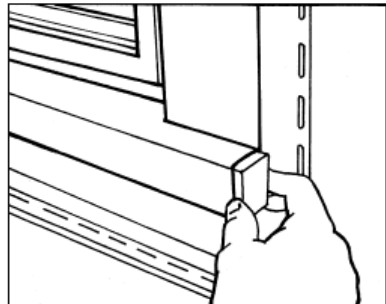

Figure 11

SIDE LINEALS

Run a bead of sealant inside both ends of the *Sill Lineal* and insert a *Sill Lineal Cap* into each end. (Figure 11)

USING THE ARCHITECTURAL ESSENTIALS TEMPLATE

The Architectural Essentials Template is designed to be used when trimming windows incorporating the sill lineal and it is necessary to fabricate the bottom face of the side lineals and the top face of the sill lineals. The template will help make the installation quicker, without the use of a tape measure.

1. Place the center tongue of the template on the locking leg side of the sill lineal as shown below, aligning one side up with the end of the lineal.
2. Trace along the center tongue and make a cut along one side only leaving a tab as shown below. Remove the locking leg on the tab.
3. Make appropriate notches in the pocket of the lineal.

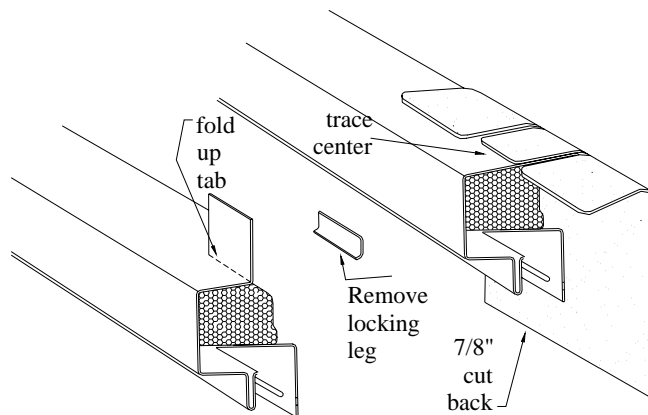

4. Place the template on the side lineal as shown below, with the edge of the template along the bottom edge of the lineal.
5. Trace both the angled side of the template and the face of the lineal. Remove this area of the lineal as shown below.
6. Continue the cut along the face of the lineal and widen the cut to approx. 1/16".
7. Make the installation in all as the top end (see standard resistant application).

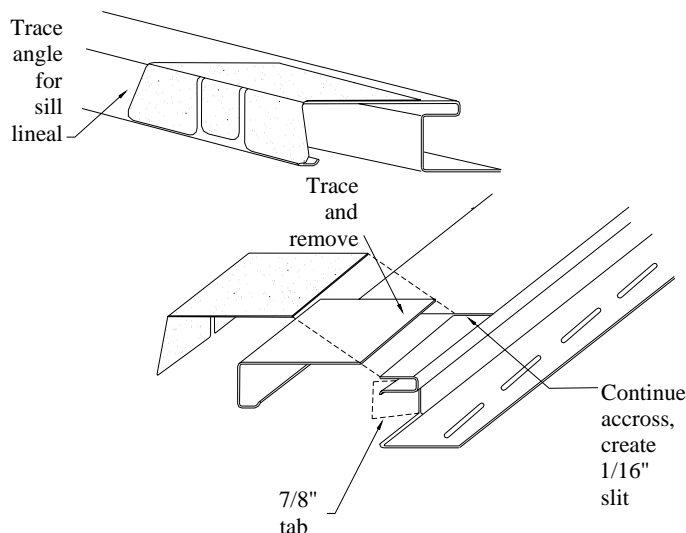

INSTALLATION OF WINDOW CROWN MOLDING

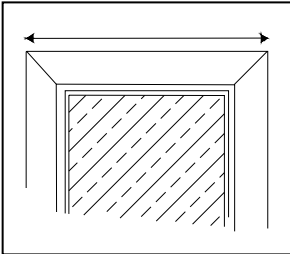

Figure 1

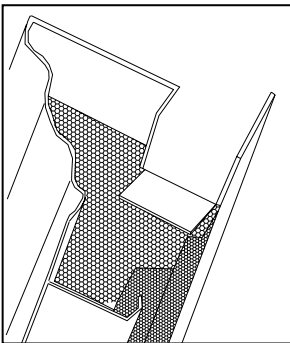

Figure 2

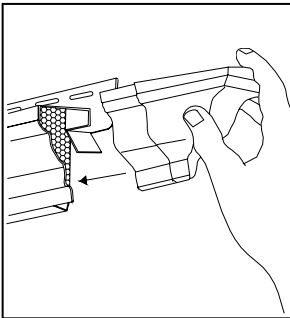

Figure 3

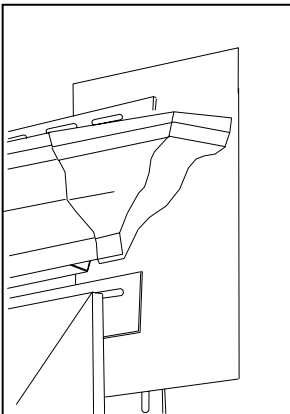

Figure 4

1. Begin by measuring from outside to outside of the window lineals or 1-1/8" J channel. Cut the Crown Molding to length. (Figure 1)
2. Cut 7/8" notches in the bottom and the J pocket of the molding on both ends. Remove the material at the bottom and create a rain tab in the J pocket. (Figure 2)
3. Glue the Window Crown End Caps into the ends of the molding using PVC cement. This is easier to do prior to the installation of the molding over the window. (Figure 3)
4. Place the Window Crown Molding into the pocket above the window. On each end of the molding place a piece of flashing as shown in figure 4. Finish by nailing the molding in the center of the nail slots every 8" to 10".

INSTALLATION OF INTEGRAL LINEAL ON WINDOWS WITH INTEGRAL J CHANNEL

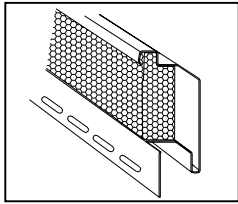

Figure 1

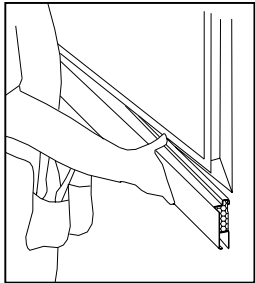

Figure 2

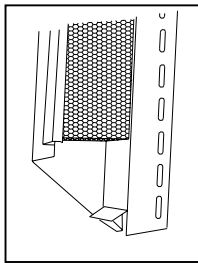

Figure 3

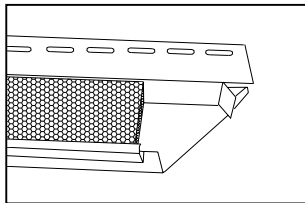

Figure 4

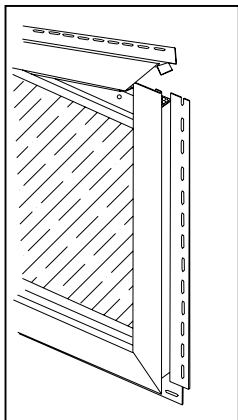

Figure 5

BOTTOM LINEAL

1. Measure the width of the window and add 7". Transfer this measurement to the lineal and cut to length.
2. On both ends of the lineal, cut 7/8" notches out of the J pocket and the insert leg. Cut back the foam to these notches. (Figure 1)
3. Insert the lineal into the bottom integral J of the window, center and temporarily tack into place. (Figure 2)

SIDE LINEALS

1. Measure the height of the window adding 7" and cut the lineals to length.
2. On what will be the top end of the lineal, cut 7/8" notches out of the J pockets and insert legs. Cut the foam back to these notches.
3. On the opposite ends of the lineal, measure 3 1/2" on the face from the end toward the J side and mark for a 45° angle. Cut the angle on the face being sure to leave the pocket of the lineal intact. Cut a 7/8" tab in the pocket. Measure and remove approximately 5/8" of the insert leg beyond the angle. Cut the foam back to this cut. (Figure 3)
4. Insert the side lineals into the integral J channel of the window, working the angle on the bottom face of the lineal over the bottom lineal and the tab into the J pocket of the bottom lineal.
5. Nail loosely every 8" to 10".

TOP LINEAL

1. Add 7" to the width of the window and cut the top lineal to length.
2. On the face of the lineal, measure back 3 1/2" on both ends. Cut the face of the lineal at 45° angles on both ends. Be sure to create water diversion tabs by cutting notches in the J pocket of the lineal on both ends. (Figure 4)
3. Install the top lineal working the angles over the side lineals. Nail loosely every 8" to 10". (Figure 5)

Finish by nailing the bottom lineal loosely every 8" to 10".

