

CRANEBOARD[®]

SOLID CORE SIDING[®] **INSTALLATION**

INSTALLING HORIZONTAL PANELS:

Cutting CraneBoard is most easily done with a circular saw using a paneling blade reversed. Saber saws, rotary saws, snips, etc. can also be used.

First Panel

Install the first panel by engaging the bottom of the panel into the starter strip. Adjust the panel to leave 1/4" gap in the corner (3/8" in temperatures below 40° F). Fasten the panel in the center of the nail slots, leaving 1/32" between the fastener and the panel to allow the panel to expand and contract. Space fasteners at 16" maximum.

NOTE: Always overlap seams away from entrances and away from the greatest traffic.

Seaming Panels

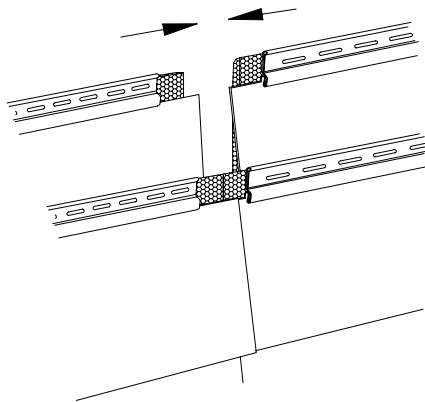

Figure 6.

- The foam is recessed and incorporates a pocket on CraneBoard for the purpose of proper seaming. To seam two panels together, slip the face of one panel between the foam and the face of the adjoining panel. Slide panels together until foam to foam contact is achieved when installing above 40°, 1/4" apart under 40°. Don't allow more than 1/4" space between ends of foam (Fig. 6).
- Seaming is most easily achieved by using factory cut ends whenever possible. If a field lap is necessary, cut back the foam approximately 3/4" on the field cut, fabricate the panel end notches, and always use a factory notch as the overlapping panel, placing the field cut end into the factory end.

Seaming Tip:

When seaming panels between windows or in tight spaces, install both panels, allowing the panel ends to just overlap. Do not nail either panel close to the seam. Pull the ends of both panels away from the wall far enough to engage the seam. Push panels back to the wall and fasten.

Continue Course Installation

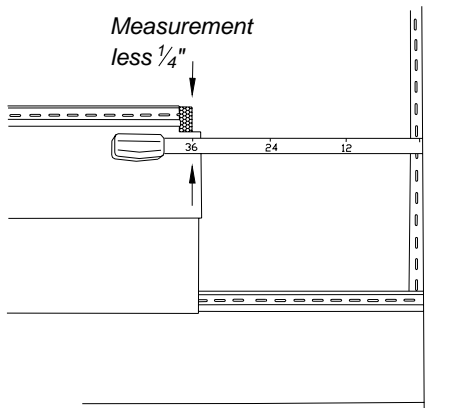

Figure 7.

- Continue installing panels fastening no more than 16" apart.
- When determining the length of the final panel of a course, measure from end of foam to corner, J channel, etc., less $\frac{1}{4}$ " ($\frac{3}{8}$ " under 40°). Transfer this measurement to the panel being careful to measure the foam, not the face of the panel. This will result in the correct panel length incorporating the gap for expansion (Fig. 7).
- Install remaining courses staggering laps so that no two laps are vertically aligned, unless separated by at least three courses.

Installing around windows, etc.

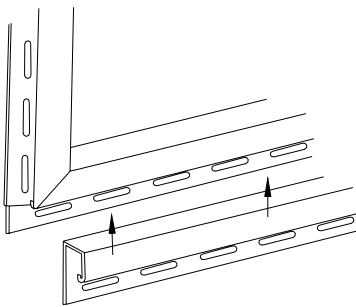

Figure 8.

- Measure and mark the panel to be cut for under the window. Add approximately $\frac{1}{4}$ " to both sides and bottom of the cut to allow for panel expansion.
- When installing CraneBoard panels under windows, use a snap lock punch to secure the panel into the J channel. Depending upon where the window cut falls on the panel, you may need to install universal J or shim out a piece of finish trim and install into the 1-1/8" under the window. Snap lock the cut edge into this trim (Fig. 8).
- Never place a seam directly below or above a window or door opening.

Top Course Installation

When installing the final course of CraneBoard, there are a few options:

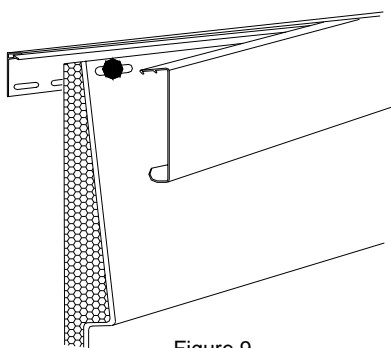

Figure 9.

- Option 1
- **Back Plate and Finish Board/Crown Molding.** This is the recommended installation for finishing a side wall. This will provide a secure and attractive installation. First, install back plate at the top of the wall nailing loosely approximately every 8" to 10". Measure the top course of siding leaving at least $\frac{1}{4}$ " to the back plate. Using a nail slot punch, punch slots every 16". Install the panel. Snap the finish board (or Crown Molding) into the back plate Fig. 9). To seam the finish board, cut 1- $\frac{1}{4}$ " off the snap leg of the overlapping piece. Overlap 1".

Top Course Installation continued

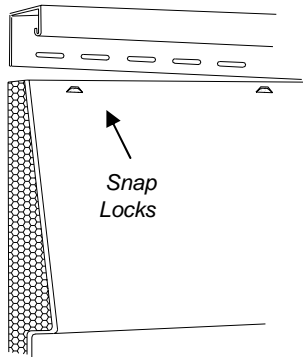

Figure 10.

Option 2

- **Use a crimping or Snap Lock Tool.** If this method is used, make certain that the panel “snaps” into the receiving J. Depending upon where the rip cut falls the receiver may be 1-1/8” J or 5/8” J. In some cases, a small strip, approx. 1-1/2” wide X 1/8” to 1/4” thick, placed in the J prior to the installation of the panel, is needed to assure positive engagement of the crimps. Measure from the soffit to the bottom of the top lock on the previous course of siding. Subtract 1/4”. Mark and cut the top course panel. Crimp the I approximately every 6” and install the panel (Fig.10).

Gable Installation

It is important to be sure the extended angles in gables are secure. The following are two options:

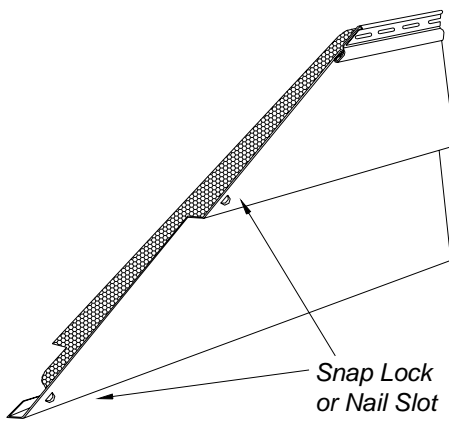

Figure 11.

Option 1

- **Back Plate and Finish Board-** When installing with Back Plate and Finish Board or Crown Molding, Use a nail slot punch to create nail slots at the end of the angle along the cut edge. Install the panel in the gable and fasten both at the nail hem as well as in the slot created by the slot punch (Fig. 11).

Option 2

- **Install 1-1/8” J channel** under overhang or eave. When installing with J channel, use a snap lock punch to create a locking tab at the bottom of the panel at the cut edge of the angle. Install the panel locking the tab into the J channel (Fig. 11).

Installation Over Deep Profile Siding

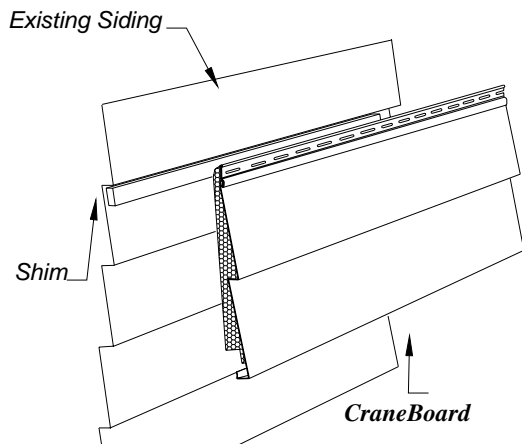

Figure 12.

- The wider coverage feature of CraneBoard siding is designed to allow installation over existing siding without first “leveling” the wall with foam underlayments or furring strips. To achieve the straightest installation possible, both horizontally as well as vertically, it may be desirable to “float” the CraneBoard panel by adjusting the depth of nailing. It can be helpful when installing over deep profile siding to place a shim under the return of the existing siding as shown in the diagram. This will also result in a firmer, more solid feel to the new siding (Fig. 12).